

SPIRIT SERIES

Motorized Electric Projection Screen

MODEL SE

What is the Spirit Series?

The Spirit Series is a collection of in-ceiling, motorized electric projection screen designed specifically for installations requiring a concealed in-ceiling projection screen on a budget. They are ideal for multi-usage environments such as hospitals, worship, conference, teaching, or training rooms where the screen needs to be hidden for aesthetic or functional reasons.

Experience Spirit

The Spirit is a series of in-ceiling electric projector screens designed for custom installation into a worship, classroom, or training room ceiling. The screen surface is fiberglass backed to greatly reduce edge curl. The perfectly flat surface is designed to last for years with minimal visual degradation.

The triangular weight bar at the bottom of the screen completely retracts into the case when it is not being used. This imitates the appearance of an expensive trap-door screen at a fraction of the price.

Smooth Operation

The Spirit can be operated in four convenient ways. A button on the case allows manual operation, the included plug-in IR receiver with remote allows semi-automatic operation, and the 5-12 volt trigger connection allows fully-automatic operation by synchronizing the screen operation with the power cycle of a compatible projector. RS-232 control also comes standard with all Spirit models.

The Spirit is equipped with a powerful motor that provides ultra-smooth, silent operation and is designed for extended durability and reliable performance.

Features

- Recessed in-ceiling installation.
- Deluxe, ultra-quiet motor.
- White, grey, or 3D materials.
- Triangular weight bar closure.
- Multiple control methods.
- Custom sizes are available.

Material Choices

All screen surfaces on the Spirit Series Model SE are fiberglass backed to reduce edge curl.

Matte White (1.0 gain): Features true color reproduction and is recommended for dark rooms.

Matte Grey (0.8 gain): Provides higher contrast for rooms with ambient lighting - perfect for classrooms and conference rooms.

SēVision 3D GX (2.2-2.4 gain): Severtson's advanced, water-based optical coating recommended for passive and active 3D projection. One of the few home theater surfaces that is RealD approved.

Who We Are

Severtson Screens is a global leader in innovative and quality projection screens for the cinema, commercial, pro AV, and home theater markets.

For more information and current pricing, visit severtsonscreens.com/register



Spirit Series
Motorized Electric Projection Screen

Recommended for
multi-use environments

Controls Included

- Manual control button
- IR Eye with extension cable
- IR Eye extension port*
- Wireless handheld IR remote control
- 12volt trigger connection by 3.5mm jack*
- Trigger cable
- RS232 control port*
- Power cable*
- Limit switch adjustment tool

*Located on the left side panel

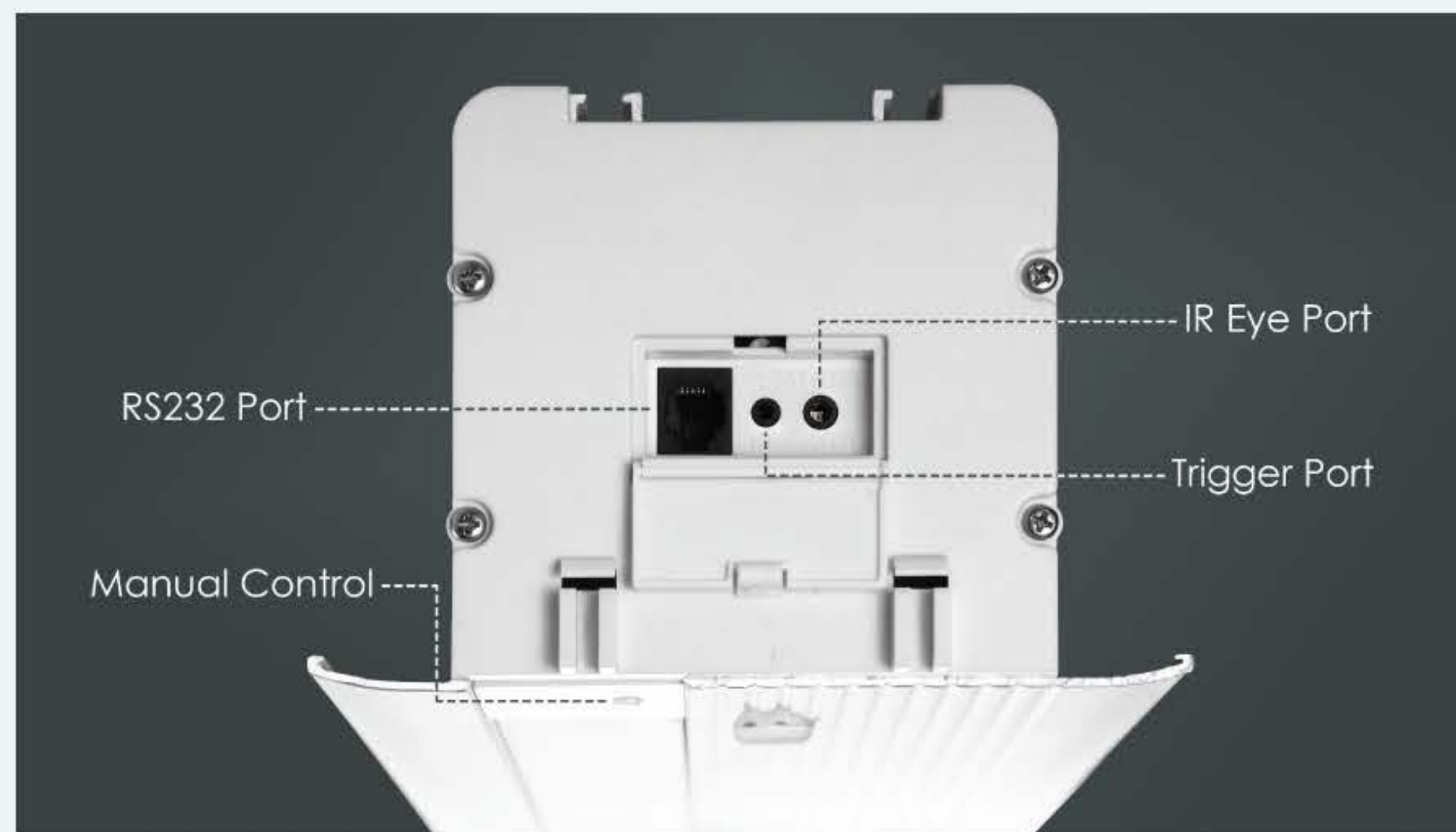

16:9 (1.777) HDTV Aspect Ratio

Model	Viewing Diagonal	Viewing Area (W x H)	In-Ceiling Dimensions
SE169092	92"	79.875" x 45.125"	6.375" x 97.75"
SE169100	100"	87" x 49"	6.375" x 105"
SE169106	106"	92.125" x 51.875"	6.375" x 110"
SE169112	112"	97.375" x 54.875"	6.375" x 115.375"
SE169120	120"	104.5" x 58.875"	6.375" x 129.125"
SE169135	135"	117.875" x 66.25"	6.375" x 136"
SE169150	150"	130.375" x 73.5"	6.375" x 148.875"



Spirit Series completely retracts into the case while not in use.

16:10 (1.6) WidePC Aspect Ratio

Model	Viewing Diagonal	Viewing Area (W x H)	In-Ceiling Dimensions
SE1610094	94"	79.875" x 49.875"	6.375" x 97.75"
SE1610103	103"	87" x 54.5"	6.375" x 105"
SE1610109	109"	92.125" x 57.5"	6.375" x 110"
SE1610115	115"	97.375" x 61"	6.375" x 115.375"
SE1610123	123"	104.5" x 66.25"	6.375" x 129.125"
SE1610139	139"	117.875" x 73.625"	6.375" x 136"
SE1610154	154"	130.375" x 81.625"	6.375" x 148.875"

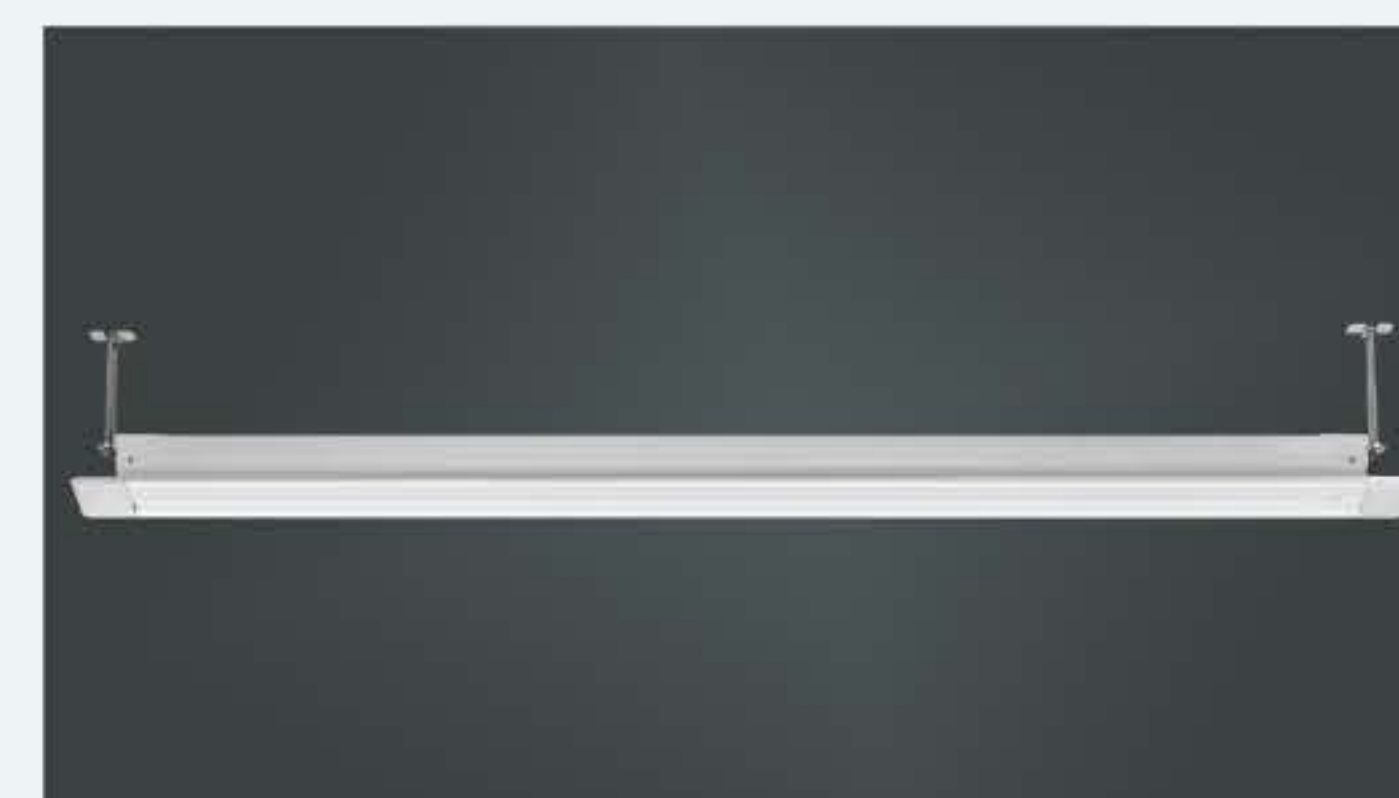

39" threaded rod (M10 - 1.5mm) included for standard in-ceiling installation.

Severtson Screens

216 S. Alma School Rd. Suite 3 Mesa, AZ 85210
Toll Free: 866-510-5155 • Phone: 480-610-5155 • Fax: 480-237-5964
sales@severtsonscreens.com

Visit Us Online

www.severtsonscreens.com
facebook.com/SevertsonScreens
twitter.com/SevertsonScreen