



# DLA-RS67U

4K Precision  
Premium Home Theater Projector

## REFERENCE SERIES



*Built with hand selected, perfectly matched components, the top-of-the-line DLA-RS67 features the industry's highest native and dynamic contrast ratios to deliver absolutely breathtaking, cinema quality images.*

- Industry's highest 150,000:1 native contrast ratio
- Intelligent Lens Aperture increases dynamic contrast ratio to industry highest 1,500,000:1
- 1080p three chip 3D enabled D-ILA projector built from hand selected components
- New 6th generation 0.7-inch D-ILA devices
- New e-shift3 4K Precision (3840 x 2160) Projected Image
- **Native 4K inputs**  
3840 x 2160 (24-30p, 60p at 4:2:0\*)  
4096 x 2160 (24p)
- Includes 2 pair of RF 3D glasses (PK-AG3) and an RF 3D Signal Emitter\* (PK-EM2)
- Clear Black processing
- Real Color Imaging Technology supports x.v.Color space and Xenon mode for authentic cinema color reproduction
- 1.4 to 2.8:1 motorized zoom lens with Horizontal and Vertical offset
- Highly customizable built-in 2D to 3D converter creates dynamic 3D images from 2D video content
- THX® and ISFccc Certified
- Control: LAN / RS-232C / IR / 12 V Screen Trigger Output / 3D Synchro Control
- New Remote Control App for smartphones and tablets
- 3 Year Warranty

\*The supplied 3D Synchro Emitter and 3D glasses are required to view 3D images.



# D-ILA® Newly Developed D-ILA Device

The exceptional picture quality achieved by JVC projectors is a result of the precision technology behind the D-ILA device. The new 6th generation device, with a 40% narrower pixel gap, achieves a 10% improvement in light efficiency for a brighter image with higher contrast and incredibly rich detail.

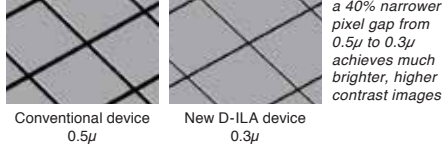

## 4K e-shift3 4K Precision JVC e-shift3 Technology

Optimized for the new D-ILA device, new 4K e-shift3 shifts sub-frames by 0.5 pixel both vertically and horizontally to achieve 4-times the pixel density of the original content—boosting definition to the highest level yet.

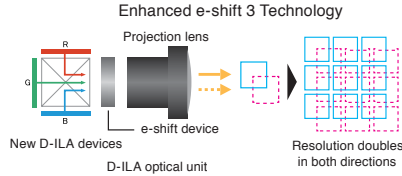

## Multiple Pixel Control (Scaler/Processor for 4K e-shift3)

The newest derivation of Multiple Pixel Control is a high-performance image processor that enables precise reproduction of Full HD sources on this 4K projector. New, Auto Mode performs frame adaptive filtering and picture generation to achieve an HD image optimized for a variety of scenes thereby enabling an immersive 4K experience without complicated picture adjustments.

### 4K e-shift3 Technology's Image Processor: Multiple Pixel Control

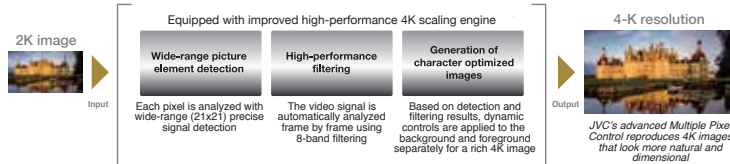

## External Dimensions (unit: inches | mm)

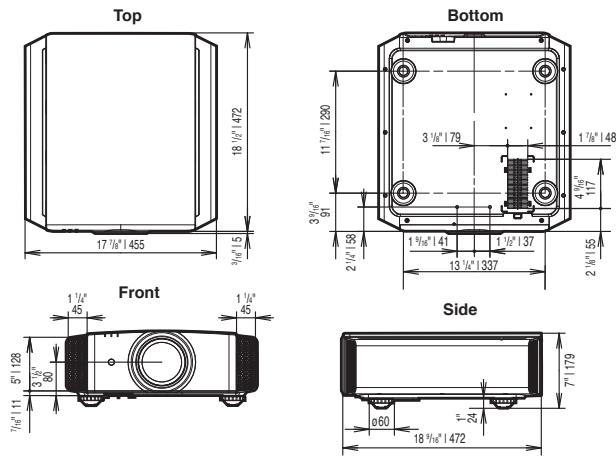

### Notes about viewing 3D video content

• The supplied 3D Synchro Emitter and 3D glasses are required to view 3D images from the D-ILA projectors. 3D video software (3D media or output of 3D broadcasts) and a 3D-compatible video player are also required. • Perception of 3D images will vary with individual viewers. • Stop viewing 3D images immediately if any discomfort such as headaches, dizziness, eye fatigue, etc. occurs. • Viewing of 3D images by children under the age of five is not recommended. • Read the Safety Precautions in the User Manual carefully before viewing any 3D source.

• The projector is equipped with a new super-high pressure mercury lamp, which may break, emitting a loud noise, when it is subjected to shock or after it has been used for some length of time. • Please note that, depending on how the projector is used, there can be considerable difference between individual lamps regarding how many hours they will operate before requiring replacement. • An additional payment is required for installation of a new lamp, if necessary. • The projector lamp requires periodic replacement and is not covered by warranty. • Please be aware that, because the D-ILA device is manufactured using highly advanced technologies, 0.01% or fewer of the pixels may be non-performing (always on or off).

Design and specifications are subject to change without notice. All pictures on this brochure are simulated. Adobe is a trademark or registered trademark of Adobe Systems Incorporated in the U.S. and/or other countries. ISF is a registered trademark of Imaging Science Foundation, Inc. THX and THX logo are trademarks of THX Ltd., which may be registered in some jurisdictions. HDMI, the HDMI logo and High-Definition Multimedia Interface are registered trademarks of HDMI Licensing LLC. All other brand or product names may be trademarks and/or registered trademarks of their respective owners. Any rights not expressly granted herein are reserved.

Copyright © 2014, JVC KENWOOD Corporation. All Rights Reserved.

## 150,000:1 Native Contrast Ratio

The combination of JVC's D-ILA device and the optical engine equipped with a new wire grid that improves polarization performance enables the DLA-RS67 to achieve the industry's highest native contrast ratio of 150,000:1\*. The newly developed Intelligent Lens Aperture optimally adjusts black levels and Clear Black boosts contrast between light and dark to achieve the industry's highest dynamic range of 1,500,000:1.



## D-ILA 3D Projection\*

There's nothing like 3D to pull you into the scene. JVC's employs an original Frame Addressing method to reproduce 3D images with vivid colors, and the optical engine featuring the new D-ILA devices achieves more brightness than ever. Furthermore, 3D image adjustment functions such as Crosstalk Canceling are featured to offer the kind of realistic and exciting 3D images that only D-ILA can provide.

\*The supplied 3D Synchro Emitter and 3D glasses are required to view 3D images.

## Smart-phone Remote Control App

Now, JVC D-ILA projectors can be controlled from your smartphone or tablet with a free remote control app. This app features an intuitive graphical UI and exclusive controls that make operations even easier. Additionally, there are built-in help functions for smoother operation.



## Accessories



## Connectors

## Specifications

		DLA-RS67
Imaging device		0.7 inch Full HD D-ILA (1920 x 1080) x3
e-shift3 Technology		Yes
Resolution		3840 x 2160 (1920 x 1080 in 3D mode)
Lens		1.4-2.8:1 Motorized Zoom & Focus f2 @ 1.4 f3 @ 2.8
Lens Shift		±80% Vertical and ±34% Horizontal (motorized)
Light Source		NSH 230W Lamp (lamp life: approx. 4000 hours when the lamp is in Low mode)
Contrast Ratio		Native: 150,000:1   Dynamic: 1,500,000:1
Connectors	HDMI	2 (3D/Deep Color/CEC compatible)
	3D Sync	1 (Mini DIN 3pin)
	RS-232C	1 (D-sub 9pin)
	LAN (RJ-45)	1
	Trigger	1 (Mini jack, DC12V/100mA)
Video Input Signal Format	Digital	480p, 576p, 720p/60/50 Hz, 1080i/60/50 Hz, 1080p/60/50/24Hz, 3840x2160/24-30 Hz, 3840x2160/60/50 Hz(4:2:0), 4096x2160/24 Hz*
3D Signal	Frame Packing	720p/50 Hz, 720p/60 Hz, 1080p/24 Hz
	Side-by-Side	1080i/60 Hz, 1080p/60 Hz, 1080i/50 Hz, 1080p/50 Hz, 1080p/24 Hz, 720p/50 Hz, 720p/60 Hz
	Top-and-Bottom	720p/50 Hz, 720p/60 Hz, 1080p/24 Hz
PC Input Signal Format	HDMI	VGA 60, VGA 59.94, SVGA 60, XGA 60, WXGA 60, WXGA+ 60, SXGA 60, WSXGA+ 60, WUXGA 60
Dimensions	(WxHxD-inches)	17 7/8 x 7 x 18 9/16
Weight (net)	(lbs)	33.07

\*4096x2160 Signal will be cropped equally on left and right side and image will be displayed 3840x2160.

DISTRIBUTED BY



referenceries.com

Printed in the U.S.A.

"JVC" is the trademark or registered trademark of JVC KENWOOD Corporation.